

# How to Fold Foldables

## Table of Contents

<u>Foldable</u>	<u>Page</u>
The 3 Tab .....	2
The Booklet .....	3
The Tri-Fold .....	4
The 4 Door .....	5
The Diamond 4 Door .....	6
Circle Inlay .....	7
Diamond / Octagon .....	8
Isosceles Triangle .....	9
The Panorama .....	10
The Six Door .....	11
The Volcano Shape .....	12

## The 3 Tab

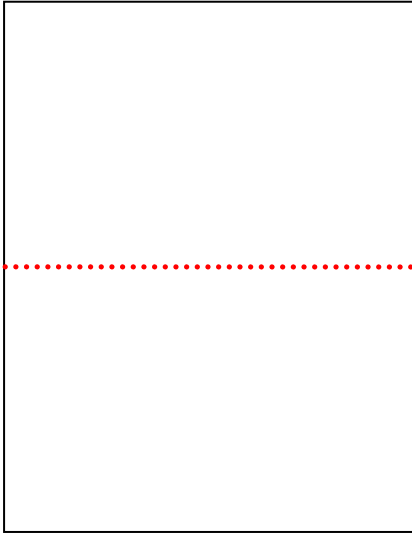

1. Fold a full sheet of paper in half and cut it so that you have 2 pieces that are  $8\frac{1}{2}$  inches by  $5\frac{1}{2}$  inches.



2. Make a fold in one of the pieces  $3\frac{1}{2}$  inches away from one of the edges.

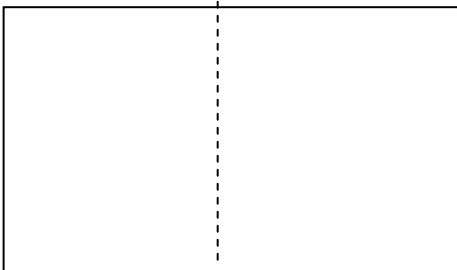

3. With the other piece, make a fold 4 inches away from one of the edges.

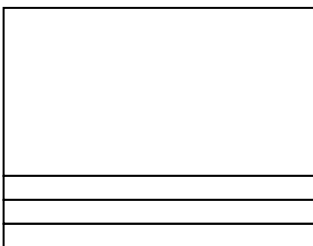

4. Insert the second piece inside the first so that it looks like this.

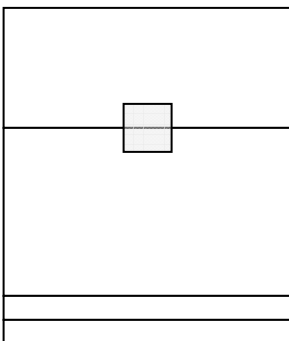

5. Open the first page and place a small piece of tape where the first page meets the second.

## The Booklet

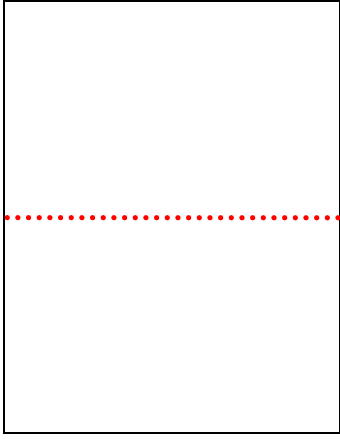

1. Fold a full sheet of paper in half and cut it so that you have 2 pieces that are  $8\frac{1}{2}$  inches by  $5\frac{1}{2}$  inches.

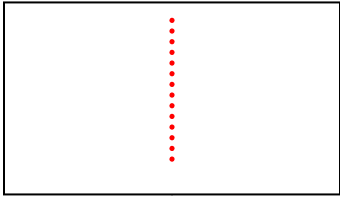

2. Fold one of the pieces in half and make a slit that goes about  $\frac{3}{4}$  of an inch away from either edge of the paper.

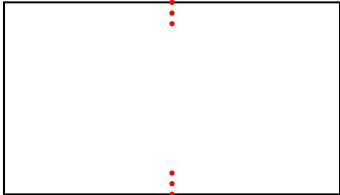

3. Fold the other piece in half and cut notches on the fold that are slightly more than  $\frac{3}{4}$  of an inch.

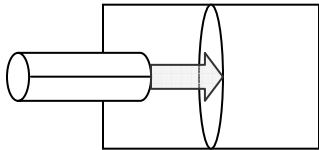

4. Roll (careful not to crease it) the notched piece and slide it halfway into the slit in the other piece.

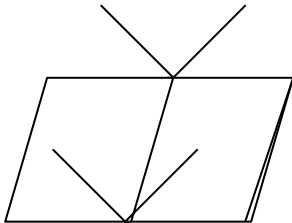

5. Straighten out the notched piece so that the notches fit into the slit in the other piece and fold it in half so that you have an eight page booklet.

## The Tri-Fold

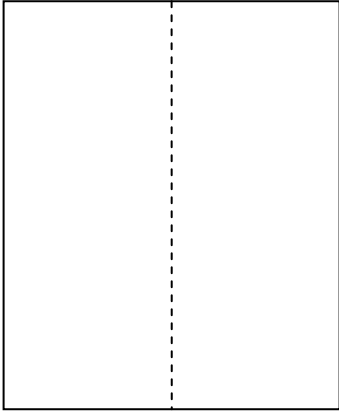

1. Fold an 8 ½ by 11 piece of paper in half the long way.

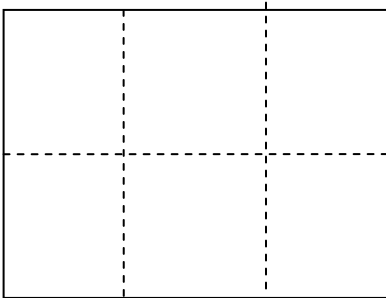

2. Hold the long way and fold it in thirds by making two folds 3 ¾ inches from the edges.

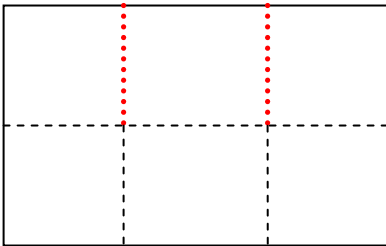

3. Cut down the two folds to the fold in the center of the paper.

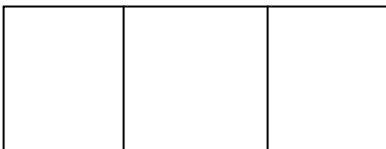

4. Fold the three flaps down.

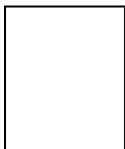

5. Fold the two side flaps on to the center panel.

## The 4 Door

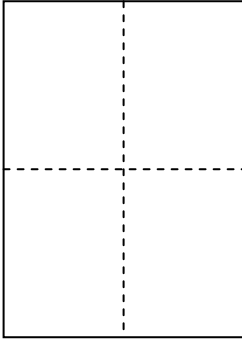

1. Fold a full sheet of paper into quarters.

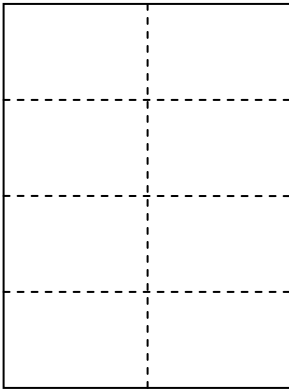

2. Make 2 folds along the short way of the paper so that it is divided into 4 equal rows.

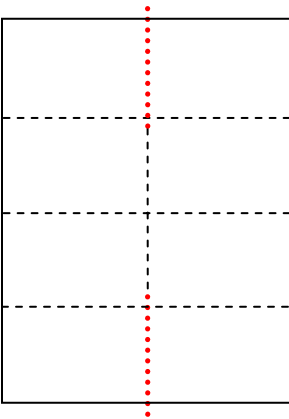

3. Cut slits into the folds at the top and bottom of the page.

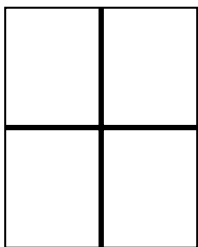

4. Fold over the flaps so that there are four “doors”. Fold that over one more time so that the “doors” hidden inside.

## The Diamond 4 Door

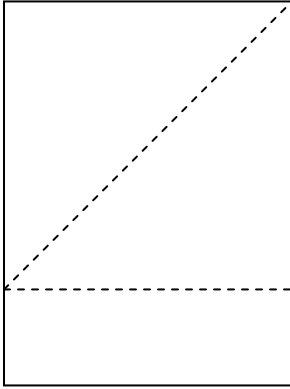

1. Fold the top edge of the paper so that it is even with the side edge of the paper. Fold the remaining flap of paper even with the edge that you have folded down.

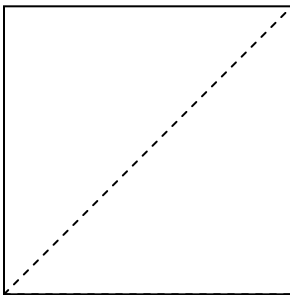

2. Cut the small flap from the bottom of the paper to make a square. Discard the small flap.

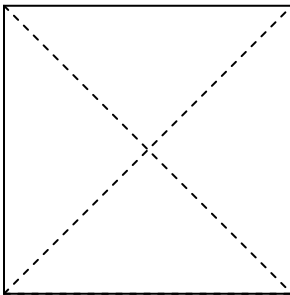

3. Fold the square so that the opposite corners touch. Unfold the paper to reveal an "X".

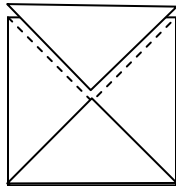

4. Fold all of the corners of the square into the center of the X.

---

## Circle Inlay

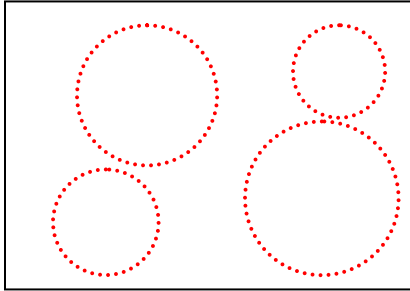

1. Cut the circles from the paper provided.

---

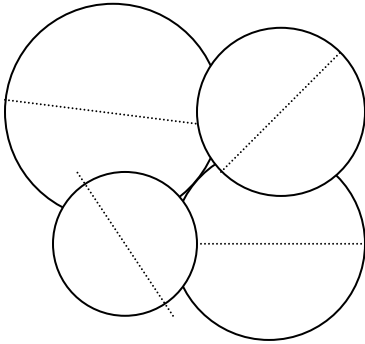

2. Fold all of the circles in half

---

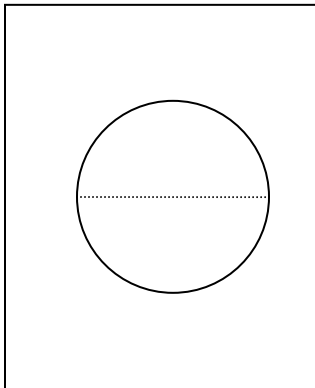

3. Paste the lower half of the largest circle to the center of a blank piece of paper.

---

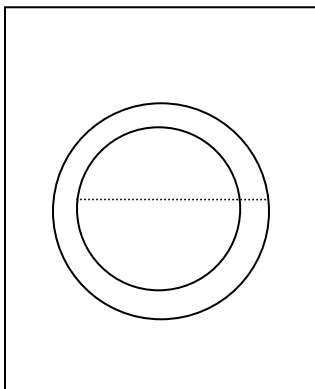

3. Paste the lower half of the next largest circle to the lower half of the largest circle. Continue to do so with the smaller circles

---

## Diamond / Octagon

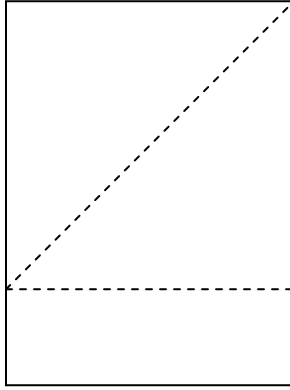

1. Fold the top edge of the paper so that it is even with the side edge of the paper. Fold the remaining flap of paper even with the edge that you have folded down.

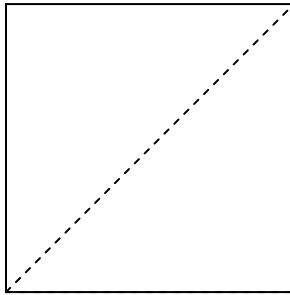

2. Cut the small flap from the bottom of the paper to make a square. Discard the small flap.

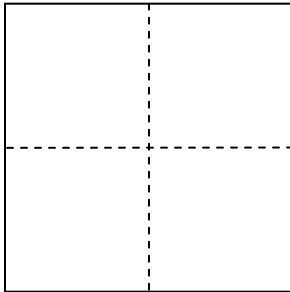

3. Fold the large square in half twice to create a small square.

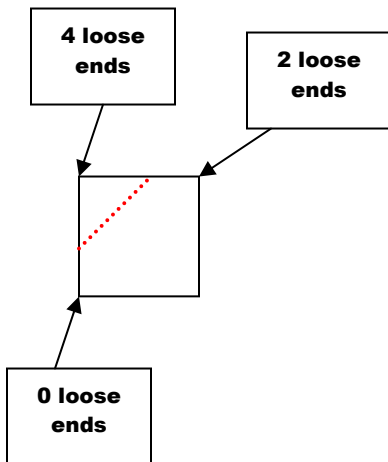

4. With the paper folded into the smaller square. Measure 4 cm from the corners indicated. Draw a line and cut across the line.

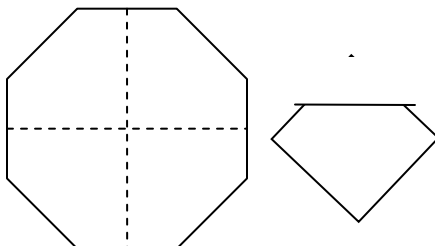

5. If the measurements and cuts were made from the proper corners you will unfold an octagon that looks like a diamond when folded up.



## Isosceles Triangle

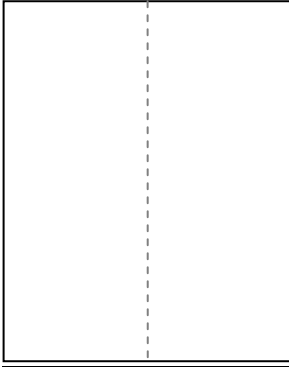

1. Fold an 8 ½ by 11 piece of paper in half the long way.

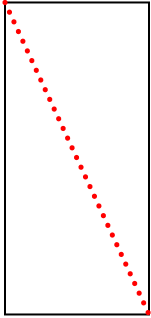

2. With the paper folded in half, use a ruler to draw a line to the opposite corners of the paper. Cut along this line.

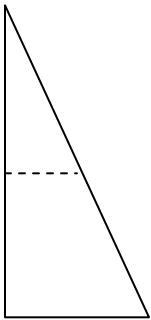

3. Keeping the paper folded in half, fold the top corner down to the corner with the right angle.

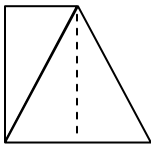

4. Fold the other corner of the triangle over to the right angle.

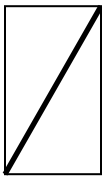

5. The end result should look like this

## The Panorama

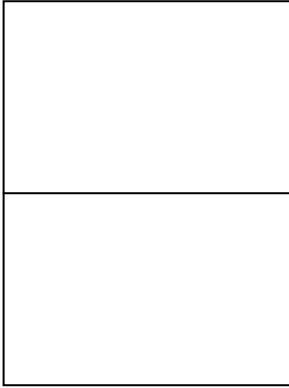

Fold a piece of 8 ½ by 11 inch paper in half the short way then cut on the fold.

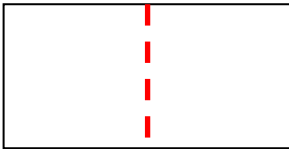

Fold each of the pieces in half.

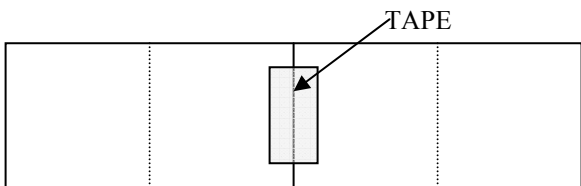
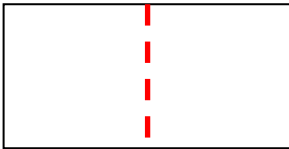

Join the two halves together end to end with a piece of tape.

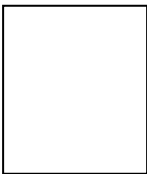

Fold the two end panels in toward the center, then fold that in half again.

## The Six Door



1. Fold an 8 ½ by 11 piece of paper in half the short way.

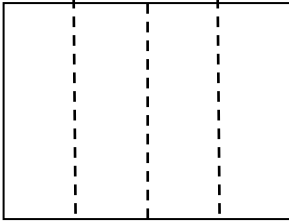

2. Now fold the paper into quarters like this.

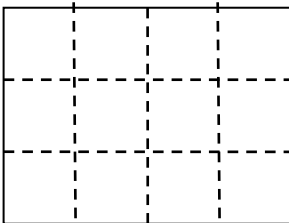

3. Fold in thirds the long way.

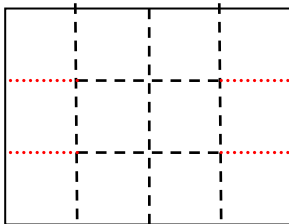

4. Cut along the two folds at either ends of the paper.

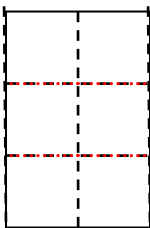

5. Fold all of the cut flaps in toward the center.

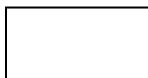

6. Fold the two side flaps in toward the center.

# The Volcano Shape

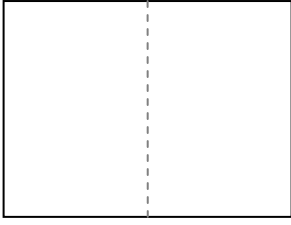

1. Fold an 8 ½ by 11 piece of paper in half the short way.

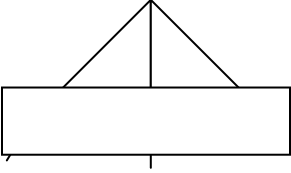

2. Fold the bottom flap up and cut the corners so that they are even with the edges of the triangle.

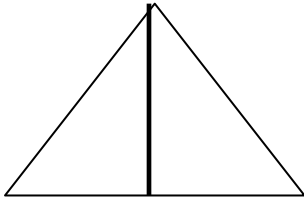

3. Fold lower flap inside the two side triangle flaps.

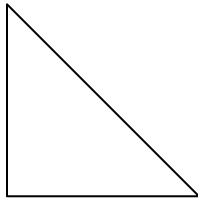

4. Fold the two side triangles into each other.



Inuit  
Alaska &  
Canada



Kwakiutl  
Pacific  
Northwest  
Coast



Pueblo  
Southwest  
New Mexico  
Arizona



Sioux  
Interior  
Great Plains

American Indian (First American) Settlement Locations



# Dinah Zike's e-Group

## Graphic Organizer of the Month

### Instructions:

1. Fold the vertical columns needed to make the table or chart.
2. Fold the horizontal rows needed to make the table or chart.
3. Label the rows and columns.

**CHART**

**TABLE**

Tables are organized along vertical and horizontal axes, while charts are organized along one axis, either horizontal or vertical.

Click on your instructional level to see photographed examples

[Elementary](#)

[Middle & High School](#)

[www.dinah.com](http://www.dinah.com)

for information on workshops and conferences, books, and upcoming events.

Use the folds in the chart or table as guides to draw easy, straight vertical and horizontal lines.

Subscribe to DinahZike

enter email address



Powered by [groups.yahoo.com](http://groups.yahoo.com)

[Manipulatives/Catalog/OrderOn-Line Workshops&Seminars/Latest News/E-Group/Quotes/Home](#)



# Elementary

Click here to return to the [E-Group](#) main page!

	Know	like to know	learned
Deciduous			
Evergreen			

adjectives	adverbs	articles	nouns
Funny small long Smart high old new far	oddly quickly roughly	a an the	dog boat tree
	a	e	i
	o	u	

Whole	Blue	Grey	Minke
Diet			
Movement			
Size			
Young			
Habitat			

Monday May 4	temperature	precipitation	wind
9:00 AM	73°	0.00"	WSW4
12:00 Noon	80°	0.00"	WSW6
2:00 P.M.	78°	0.00"	W9

Food Table	night	noon	morning	snacks
Monday	rice beans eggs	peanut butter and jelly candy hotels chips	corn fruit orange juice	The Land cheese chip candy ice cream
Tuesday	Hot Lunch washed bananas green beans Red r.Aid			
Wednesday				
Thursday				
Friday				

Chapter Two	Main Ideas	Vocabulary	Visuals → Date
Lesson 1			
Lesson 2			
Lesson 3			

Rational Numbers	+	-	×	÷
Fractions				
Decimals				
Percentages				

<	Number	>
4, 8, 9, 24	25	28, 93, 101
47, 48, 49	50	51, 52, 53

Civil War	Industry	Economy	Slavery
North	Industrial	Supported high tariffs struggling	Anti-slavery
South	Agricultural	Supported low tariffs prosperous	Pro-slavery

[Manipulatives/Catalog/Workshops&Seminars/](#)  
[Latest News/E-Group/Quotes/Home](#)



Click here to return to the [E-Group](#) main page

# Middle & High School

Shapes	Perimeter	Area

Number	whole number?	integer?	rational number?
-3	✓	✓	✓
18	✓	✓	✓
-8 1/2	✓	✓	✓

Rocks	Examples	Formation	Types of...
Igneous			
Sedimentary			
Metamorphic			

Rivers	Location	Length	Flora/Fauna
Nile	Africa	4,132mi	Elephants, Crocodiles
Amazon	South America	4,000mi	Amphibians, jaguars, monkeys, toucans, sloths
Mississippi	North America, United States	2,340mi	Cypress trees, alligators
Yangtze	Asia	3,915mi	Wild-tanned River Dolphins
Murray-Darling	Australia	1,600mi	gum trees, Australian Kang

Western Hemisphere	North America	Central America	South America
1600's			
1700's			
1800's			
1900's			
2000's			

Facts	Opinions	Biases
Examples		
Descriptive		
Narrative		
Persuasive		
Expository		

Exactly 2 Factors	Exactly 3 Factors	Exactly 4 Factors	Exactly 5 Factors	Exactly 6 Factors
2	4	6	16	12
3	9	8		18
5				20
				28
				32
				44
				45
				50

  

Number	Scientific Notation
687,000	$6.87 \times 10^5$
60,000,000	$5 \times 10^7$
.0000056	$5.6 \times 10^{-6}$

Number of Sides	Quadrilateral	Pentagon	Hexagon	Heptagon	Octagon
Sides	4	5	6	7	8
Diagonals	1	2	3	4	5
Triangles	2	3	4	5	6



# West African Societies

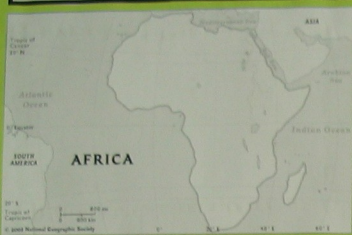

## Conflict

## Cooperation

**Motivating Forces**

**Obstacles**

**Accomplishments**

# European Exploration in North America & West Africa

Francisco Coronado:  
southwest United States

Conquered and enslaved American Indians  
Brought Christianity to the New World

Francisco Coronado: Spain



Samuel de Champlain Robert La Salle  
Quebec Mississippi River Valley



Established trading posts  
Spread Christian religion

Samuel de Champlain & Robert La Salle France



John Cabot: eastern Canada



Established settlements & claimed land  
Learned farming techniques from American Indians  
traded

John Cabot: England

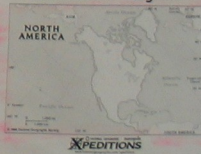

XPEDITIONS



# Dinah Zike's e-Group

## Graphic Organizer of the Month

### Instructions:

1. Fold a sheet of paper in half horizontally (hamburger) so that one side is one inch longer than the other side.

2. Cut the shorter side in half, up towards the fold (mountain top) to create two flaps.

### Focus Skill: Causes & Effects

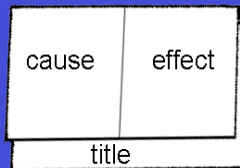

Encourage students to add personal opinions or observations when appropriate

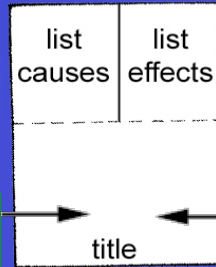

Write a paragraph or sentences summarizing a specific cause and effect

Click on your instructional level to see photographed examples

[Elementary](#)

[Middle & High School](#)

[www.dinah.com](http://www.dinah.com) for information on workshops and conferences, books, and upcoming events.

Subscribe to DinahZike

enter email address



Powered by [groups.yahoo.com](http://groups.yahoo.com)

[Manipulatives/Catalog/OrderOn-Line](#)  
[Workshops&Seminars/Latest News/E-Group/Archives/Quotes/Home](#)



# Elementary

Click here to return to the [E-Group](#) main page!

## Cause and Effect Ideas for Elementary Levels:

- leaf color change
- human growth
- night and day
- wind
- a growing community
- extinction of the Dodo bird or an animal becoming endangered
- water pollution
- exploration
- a character's actions in a story
- water cycle

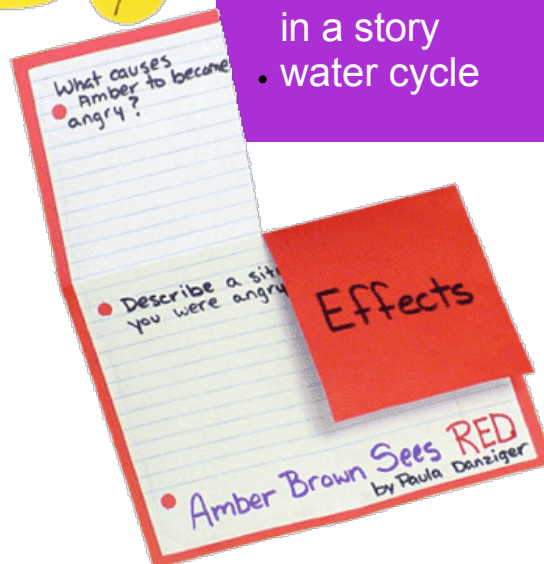



Click here to return to the [E-Group](#) main page

# Middle & High School

## Cause and Effect Idea Juggers for Middle & High School:

- westward expansion
- immigration
- industrial revolution
- Vietnam War
- disease (could be a specific one such as malaria)
- dominant traits
- erosion
- heat transfer or molecular movement and/or nuclear fusion
- mechanical waves
- literature based upon social issues, protests, or propaganda
- patriotic writings

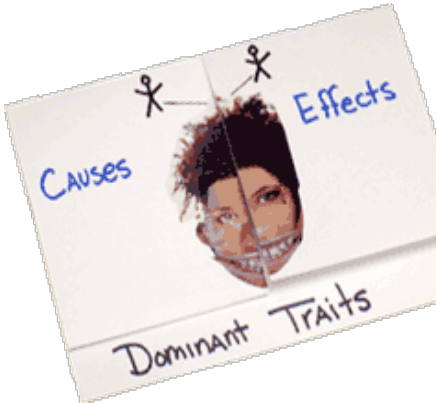
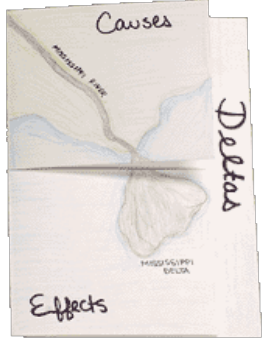
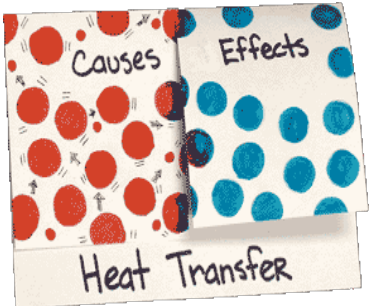
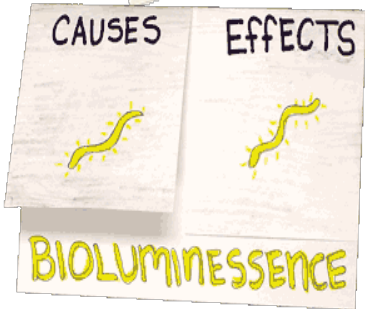

# United States



Appalachian Mountains



Coastal Plain



Great Plains



Rocky Mountains

1  
Atlantic and Pacific

2  
Rivers to know

3  
Lakes and gulfs to know

4  
Water features are used for...

5  
Atlantic and Pacific Oceans provide access to...

6  
Atlantic Ocean served as...

7  
The Ohio River was the...

8  
Inland port cities grew in the Midwest...

9  
The Mississippi and Missouri Rivers were transportation arteries for...

10  
The Mississippi and Missouri Rivers were links to....

11  
The Columbia River was explored by...

12  
The Colorado River was explored by ...

13  
The Rio Grande River forms the border with...

14  
Early in U.S. history, the Pacific Ocean was an...

15  
The Gulf of Mexico provided the French and Spanish with...



Engaging Students  
With Foldables  
US History to 1877  
41<sup>st</sup> Annual Conference  
Virginia Social Studies Educators  
November 4, 2005



Presented by  
Susie Orr, Elementary Social Studies Specialist  
Fairfax County Public Schools  
[Susan.Orr@fcps.edu](mailto:Susan.Orr@fcps.edu)  
703-846-8703

This packet contains foldable templates that were modeled after the folding techniques of Dinah Zike. These models correlate to specific Virginia SOL objectives and essential knowledge for United States History to 1877. The CD in your folder contains templates for every unit in US History to 1877, plus photos of foldable models. It is strongly recommended that when sharing the templates with colleagues, you either demonstrate the folding techniques or refer to Dinah's book.

A reference book, *Dinah Zike's Big Book of United States History*, or *Dinah Zike's Big Book of Social Studies*, includes clear technique directions on how to complete each of the folds used in these templates.

*Dinah Zike's Big Book of Social Studies, Elementary K-6*  
ISBN # 1-882796-20-9 Stock Number: CCC103

*Dinah Zike's Big Book of United States History*  
ISBN 1-882796-24-1 Stock Number: CCC107

Dinah's books can be ordered directly from:

[www.dinah.com](http://www.dinah.com) 1-800-99-DINAH

## MAPS

Maps are often used with the foldables. The maps included in the templates are from Mapmaker Toolkit and National Geographic. The Mapmaker Toolkit maps can only be duplicated if your school has a site license for this program. Maps can also be downloaded from other map sources such as:

[www.eduplace.com/ss/maps](http://www.eduplace.com/ss/maps)

[www.nationalgeographic.com/xpeditions/atlas](http://www.nationalgeographic.com/xpeditions/atlas)

[www.lib.utexas.edu/maps/](http://www.lib.utexas.edu/maps/)



# The Folding Techniques

Today, we will practice a variety of folds used in the templates on the CD. There will not be time to make each template, but by practicing the different folds, participants should be able to easily make all the templates on the CD.

1. Two-Tab Book - USI.4b Cultural Interaction
2. Three-tab with Venn diagram - USI.7c Emergence of Two Political Parties
3. Five-Tab Book- USI.3 Locating American Indians
4. Shutter Fold - USI.6b Key Philosophies in the Declaration of Independence
5. Four-Door - USI.5a Factors Leading to Colonization
6. Matchbooks - USI.2b Geographic Locations
7. Tiny Flip Ups- USI.2c Locate and Identify Water Features
8. Bound Book - USI.6c Key people of the Revolution
9. Pocket-Book - USI.9d Roles of Civil War Leaders
10. Accordion Fold - USI.4a Explorers
11. Layered Look Book USI.6c- Key Events of the Revolution
12. Pocket Book Extra - Tarry Lindquist style

## General Tips:

- Use bright colorful paper, such as Wausau Paper Astrobrights, available at office supply stores such as Office Depot, or Staples. Costco also offers a pack of brightly colored paper at a reasonable price.
- Glue sticks make for less mess and less wrinkles. Wet glue makes for longer lasting strength. Choose what works best for you and your students.
- Store foldables in a zipper lock bag. Write names, objective numbers, or other information with a Sharpie, then place clear packing tape over the writing to preserve. Clip corners to let air out and keep flat.
- Make models for yourself and store them by unit/objective #. Glue the objective and objective number on the back of the teacher models. Some teachers like to glue the direction sheet to the back.

# Sentence Strips

1. Take two sheets of paper (8 1/2" x 11") and fold into *hamburgers*. Cut along the fold lines making four half sheets. (Use as many half sheets as necessary for additional pages to your book.)
2. Fold each sheet in half like a *hot dog*.
3. Place the folds side by side and staple them together on the left side.
4. One inch from the stapled edge, cut the front page of each folded section up to the mountain top. These cuts form flaps that can be raised and lowered.

**NOTE:** To make a half cover, use a sheet of construction paper one inch longer than the book. Glue the back of the last sheet to the construction paper strip, leaving one inch on the left side to fold over and cover the original staples. Staple this half cover in place.

